

MITSUBISHI

Industrial Sewing Machine

TECHNICAL INFORMATION

Automatic Undertrimmer, Single-Needle Lookstitch

Model LS2-180

ET-022



CONTENTS

| | |
|---|--------|
| 1. CONSTRUCTION..... | 2 |
| 2. SPECIFICATIONS | 3 |
| 3. THREAD TRIMMER SYSTEM..... | 4 ~ 6 |
| 3.1 Electric Section..... | 4 |
| 3.2 Machine Head Section..... | 5 |
| 4. PREPARATIONS BEFORE OPERATION | 7 ~ 8 |
| 4.1 Installation of Sewing Machine and Motor | 7 |
| 4.2 Adjustment of Machine Stop Position..... | 8 |
| 5. ADJUSTMENTS..... | 9 ~ 15 |
| 5.1 Thread Trimmer Mechanism | 9 |
| 5.1.1 Construction | 9 |
| 5.1.2 Cautions on adjustment..... | 9 |
| 5.1.3 Installation of knife base and fixed blade bracket unit | 9 |
| 5.1.4 Connection of knife base and knife driving crank | 10 |
| 5.1.5 Knife driving shaft and related parts | 10 |
| 5.1.6 Installation of thread trimmer solenoid unit | 11 |
| 5.1.7 Installation of thread trimmer cam | 11 |
| 5.1.8 Adjustment of knife engagement..... | 12 |
| 5.1.9 Adjustment of needle thread tension releasing amount..... | 13 |
| 5.2 Adjustment of Needle Thread Remaining Length | 13 |
| 5.3 Cautions on Installation of Touch-Back Solenoid | 13 |
| 5.4 Touch-Back Pushbutton | 13 |
| 5.5 Wiper..... | 14 |
| 5.5.1 Height of wiper..... | 14 |
| 5.5.2 Wiper operation position..... | 14 |
| 5.6 Adjustment of Forward and Reverse Stitch Lengths..... | 14 |
| 5.7 Adjustment of Feed Dog Inclination..... | 14 |
| 5.8 Timing of Feed | 15 |
| 5.9 Hook, Bobbin Case, and Bobbin | 15 |
| 6. TROUBLESHOOTING..... | 16 |

1. CONSTRUCTION

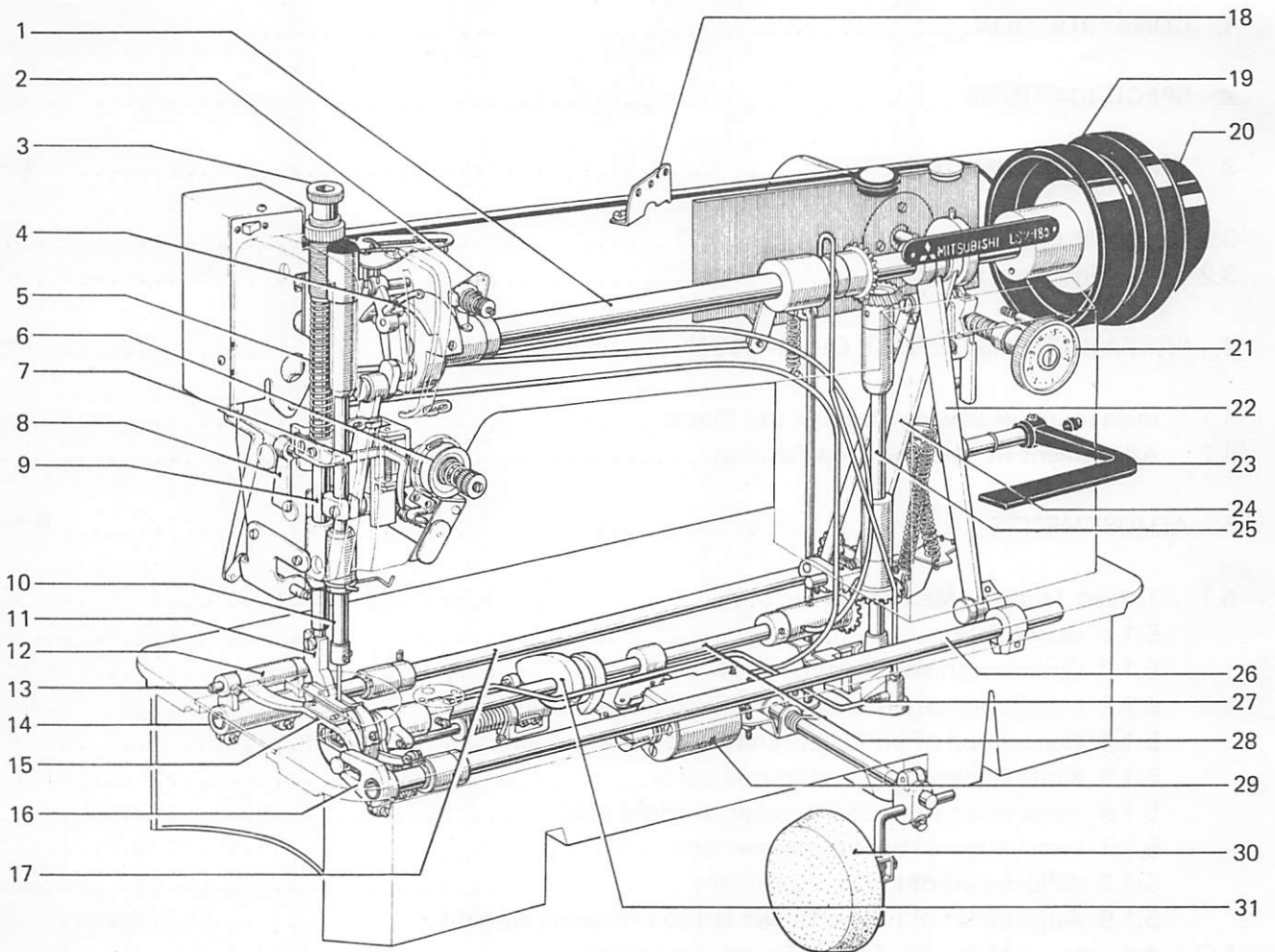

Major Part Names

- | | | |
|-----------------------------------|----------------------------------|---------------------------------------|
| 1. Arm shaft | 2. Pretension | 3. Presser bar regulating thumb screw |
| 4. Take-up lever | 5. Presser bar spring | 6. Tension regulator |
| 7. Thread guide | 8. Presser bar lifter | 9. Presser bar |
| 10. Needle bar | 11. Presser foot | 12. Feed bar |
| 13. Eccentric shaft | 14. Feed rock shaft crank (left) | 15. Feed dog |
| 16. Feed lifting fork | 17. Feed rock shaft | 18. Thread guide |
| 19. Balance wheel | 20. Synchronizer | 21. Feed regulating dial |
| 22. Connecting rod (feed lifting) | 23. Reverse sewing lever | 24. Connecting rod (feed rock) |
| 25. Vertical shaft | 26. Feed lifting rock shaft | 27. Lubricating pump |
| 28. Hook shaft | 29. Thread trimmer solenoid | 30. Knee lifter |
| 31. Thread trimmer cam | | |

2. SPECIFICATIONS

| Item \ Model | LS2-180-MIT | LS2-180-MITW | LS2-180-HIT | LS2-180-BIT |
|---|---|--------------|--|---|
| Material weight | Light to medium heavy | | Heavy | Heavy |
| Max. sewing speed, spm | 5,000 | | 3,500 | 3,000 |
| Max. stitch length, mm | 0 to 4 | | 0 to 7 | |
| Needle bar stroke, mm | 31.8 | | 33.0 | 35.0 |
| Presser foot stroke, mm Knee lifter/Manual | 11/6 | | | 13/6 |
| Needle | DBX1-2 #14 | | DBX1 #22 | |
| Hook | Fully-rotating automatic lubrication Standard (for thread trimmer) | | Fully-rotating, automatic lobrication Hevy (for thread trimmer) | Fully-rotating, automatic lubrication Hevy, large (for thread trimmer) |
| Bobbin case | With idle running prevention spring Standard | | With idle running prevention spring Heavy | With idle running prevention spring Large |
| Bobbin | Made of aluminum, for thread trimmer | | Made of steel, for thread trimmer | Made of steel, for thread trimmer, large |
| Thread trimmer | Rotary scissoring by levt movable knife and right fixed blade | | | |
| Thread trimmer starting | Solenoid actuation | | | |
| Knife drive | Cam drive | | | |
| Touch-back | ○ | | | |
| Wiper | — | ○ | — | — |

3. THREAD TRIMMER SYSTEM

3.1 Electric Section LS2-180-MITW

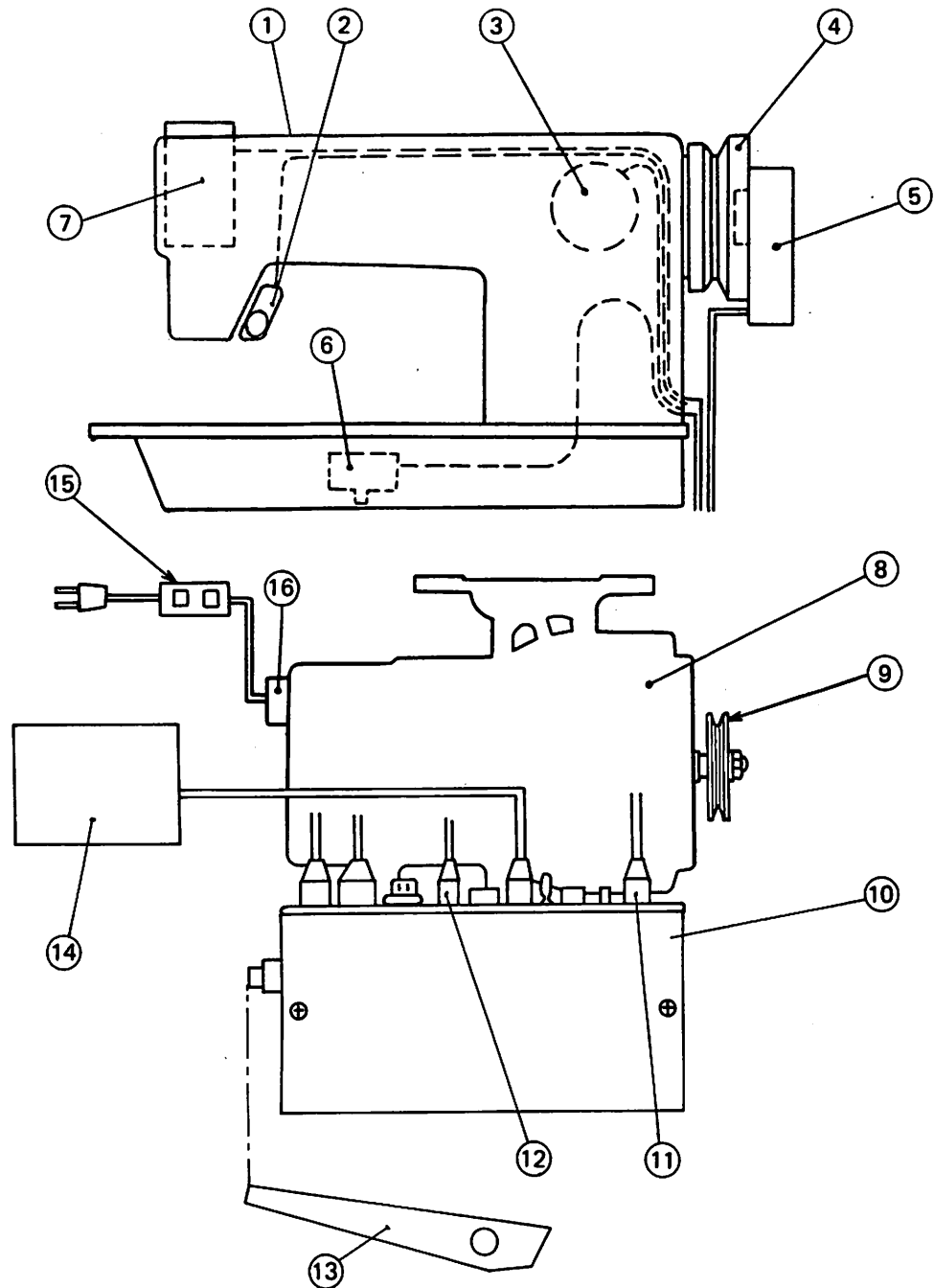

Part Names

- | | | |
|------------------------|---------------------|---------------------------|
| ① Sewing machine | ② Touch switch | ③ Back solenoid |
| ④ Balance wheel | ⑤ Synchronizer | ⑥ Thread trimmer solenoid |
| ⑦ Wiper solenoid | ⑧ Motor | ⑨ Drive pulley |
| ⑩ Control box | ⑪ Machine cord plug | ⑫ Synchronizer cord plug |
| ⑬ Pedal | ⑭ Switch panel | ⑮ POWER ON/OFF pushbutton |
| ⑯ Phase reversing plug | | |

3.2 Machine Head Section (1)

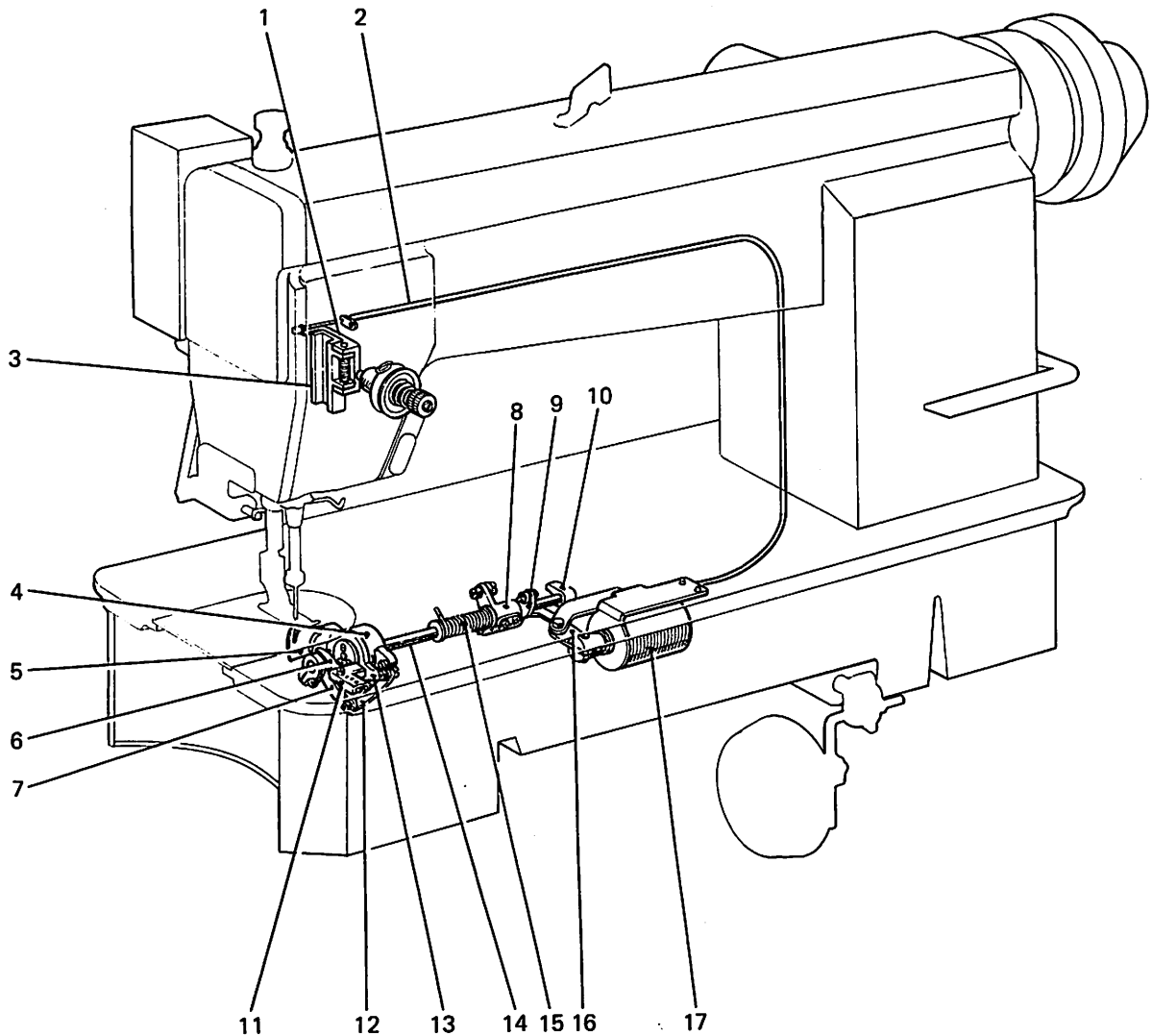

Part Names

- | | | |
|---------------------------|-----------------------------|-------------------------------------|
| 1. Thread tension release | 2. Flexible wire | 3. Needle bar connecting link guide |
| 4. Pedestal | 5. Movable knife (left) | 6. Fixed blade |
| 7. Knife driving crank | 8. Cam follower crank (1) | 9. Cam follower crank (2) |
| 10. Stopper | 11. Fixed blade bracket | 12. Link |
| 13. Knife base (left) | 14. Knife driving shaft | 15. Coil spring |
| 16. Driving lever | 17. Thread trimmer solenoid | |

3.2 Machine Head Section (2)

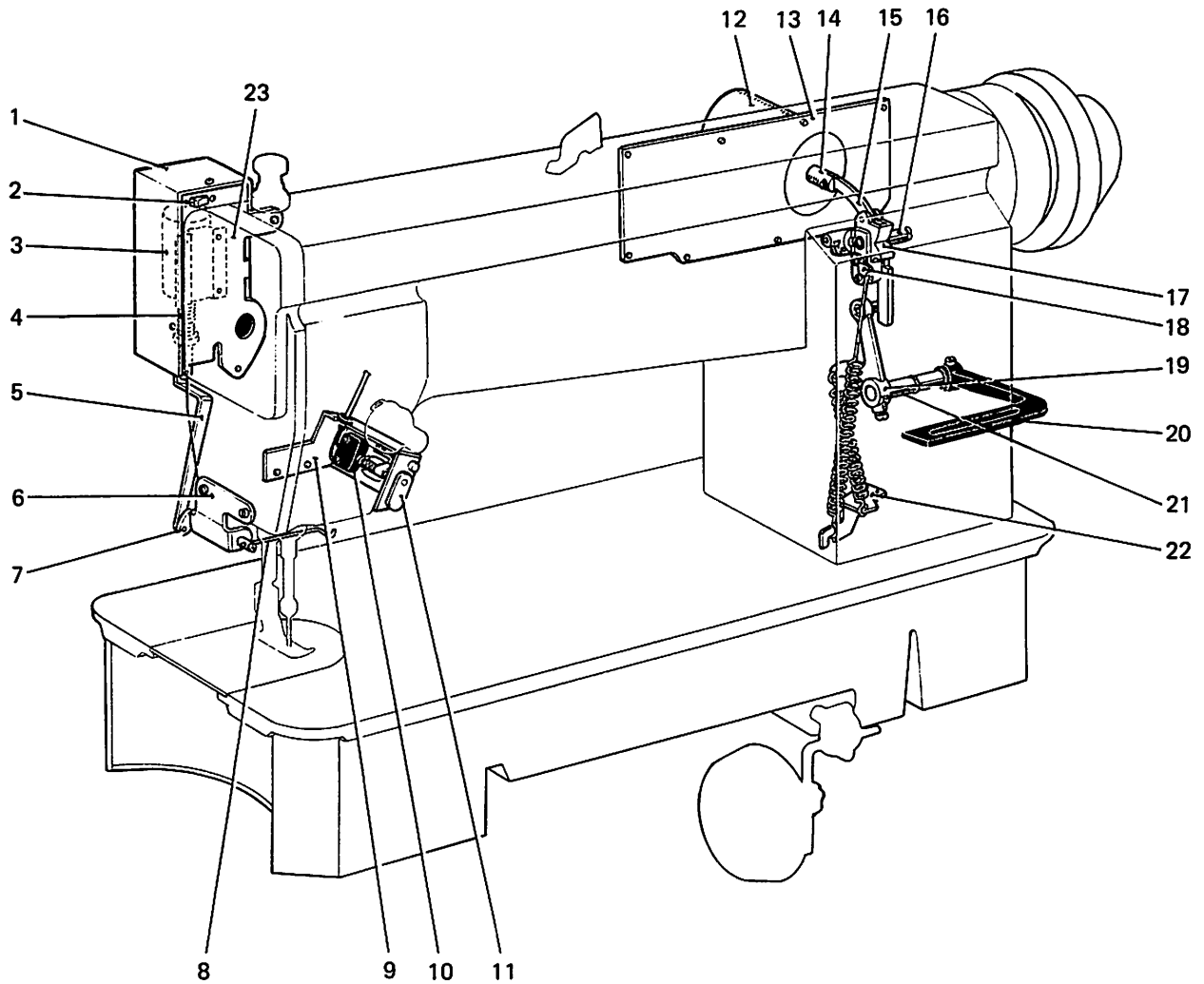

Part Names

- | | | |
|--------------------------|-------------------------------|------------------------|
| 1. Cover | 2. Switch | 3. Wiper solenoid |
| 4. Coil spring | 5. Link | 6. Wiper bracket |
| 7. Pin | 8. Wiper | 9. Switch bracket |
| 10. Micro switch | 11. Pushbutton | 12. Back solenoid |
| 13. Side cover | 14. Plunger | 15. Link |
| 16. Bushing | 17. Feed regulator cam | 18. Spring bracket |
| 19. Reverse sewing crank | 20. Reverse sewing lever | 21. For reverse sewing |
| 22. Spring bracket | 23. Solenoid mounting bracket | |

4. PREPARATIONS BEFORE OPERATION

4.1 Installation of Sewing Machine and Motor

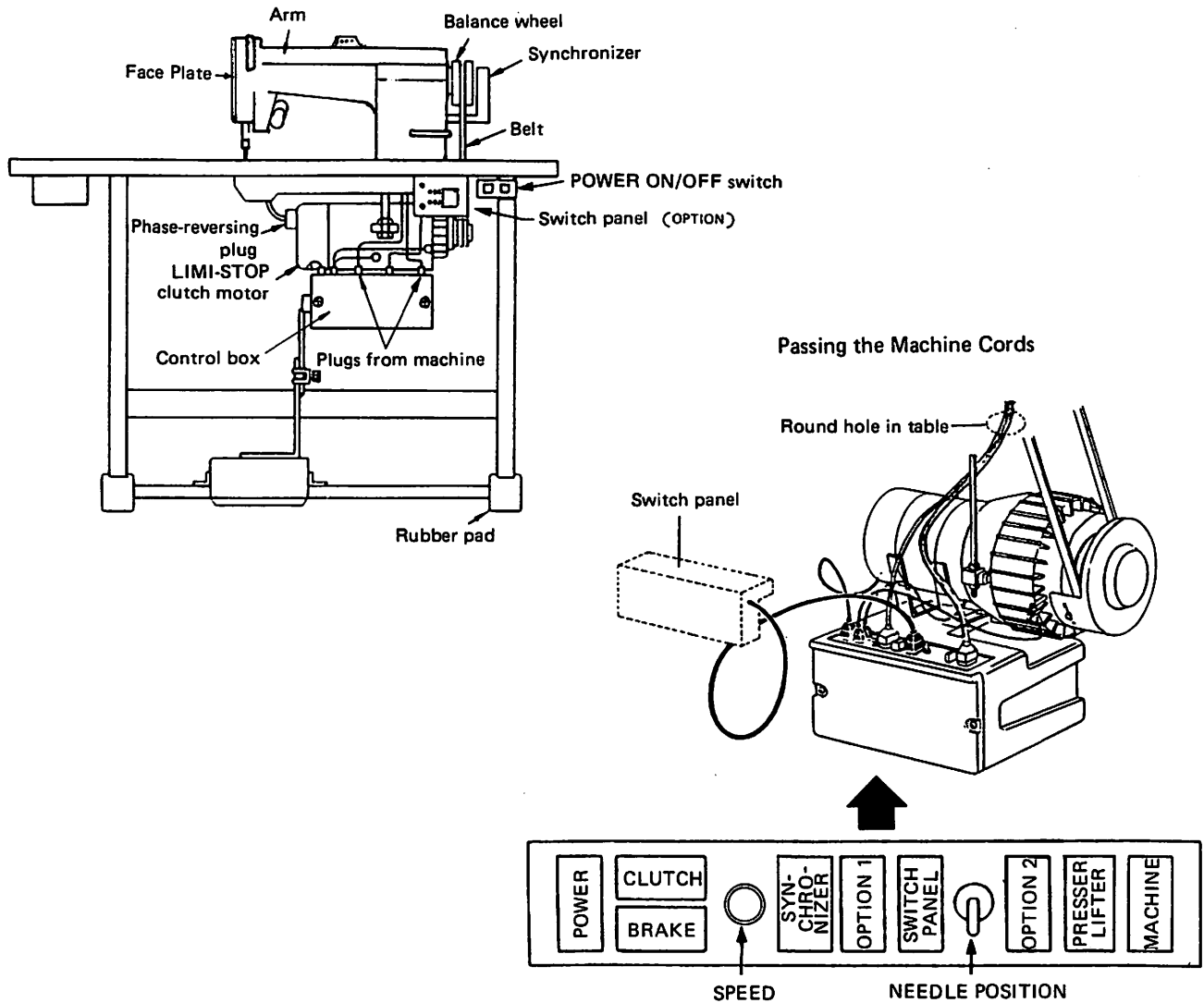

Wiring between sewing machine and control box

Note: Before plugging or unplugging, be sure to turn off the **POWER ON/OFF** pushbutton. Pass two cables from the sewing machine through the round hole in the table and connect the two plugs into the respective plug receptacles.

4.2 Adjustment of Machine Stop Position

After thread trimming is completed by heeling the pedal, the sewing machine is brought to a stop with the timing mark (B) aligned with the first timing mark (C). The sewing machine is fully factory-adjusted. However, if the marks are misaligned more than 3 mm, adjust the setting position of light shielding disc as described below.

[Preparation]

1. Disconnect the plug (12 pins) of cord, which comes out of the machine head, from the controller.
2. Remove the synchronizer cover.
3. Operate the sewing machine and stop it at the needle UP position. In this state, make the following adjustment.

[Adjustment]

1. While holding the light shielding disc by hand, turn the balance wheel to match the timing marks (B) and (C).
2. Perform the toe-down and heeling operations of pedal several times to check if the stop position has been stabilized.
3. When the stop position has been stabilized, connect the plug (12 pins) coming out of the machine head.

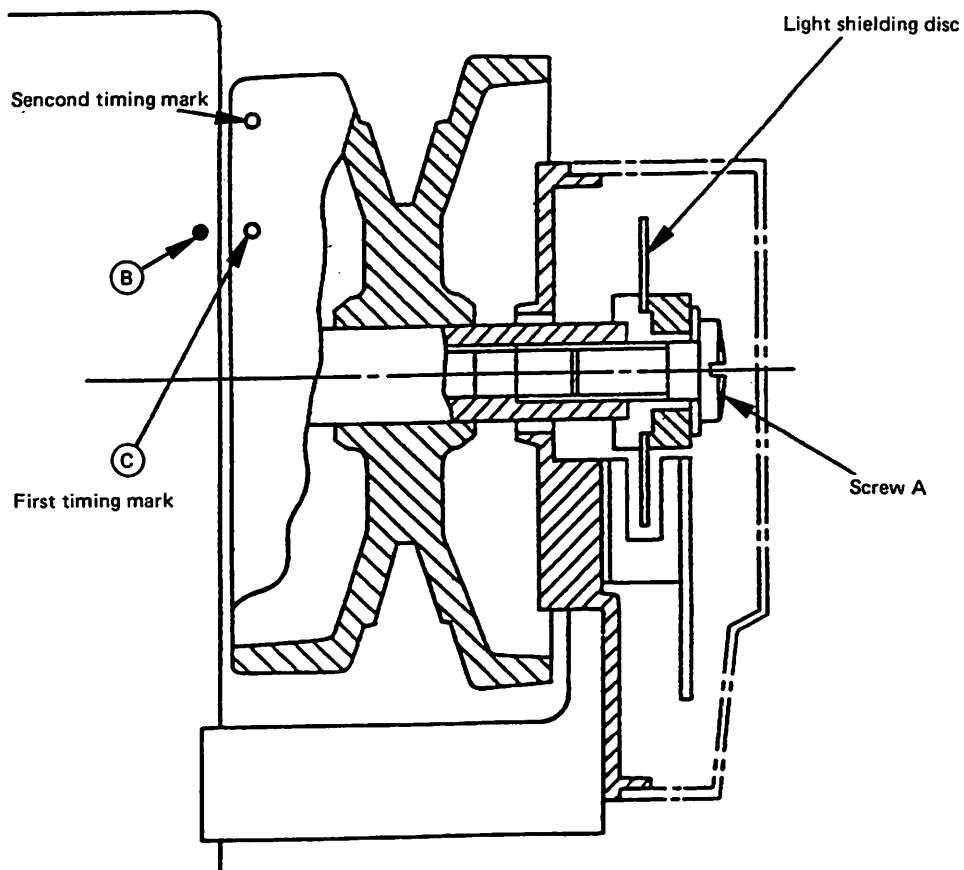

5. ADJUSTMENTS

5.1 Thread Trimmer Mechanism

5.1.1 Construction

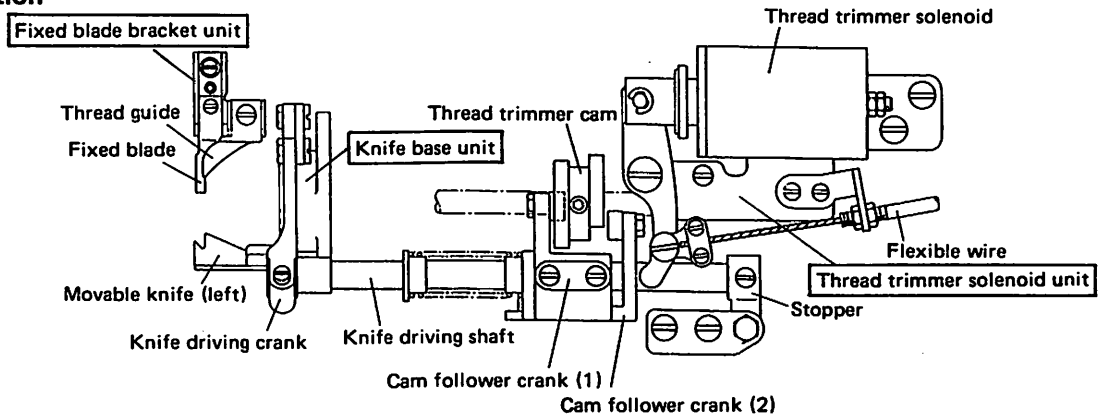

Fig. 1

5.1.2 Cautions on adjustment

A hook shaft cam system is utilized for the thread trimmer drive. Therefore, during the adjustment of sewing machine, if the sewing machine is rotated one turn with the thread trimmer solenoid in the operating state (the roller of cam follower crank (2) is engaged with the thread trimmer cam), the movable knife makes contact with the needle, resulting in damage. Be sure to bring the solenoid into the operating state only during a normal thread trimming cycle (Needle DOWN position to UP position).

5.1.3 Installation of knife base and fixed blade bracket unit

5.1.3.1 Knife base unit

- (1) As shown in Fig. 2, fit the knife base unit to the hook shaft bushing (left) and fix with the screws (A).

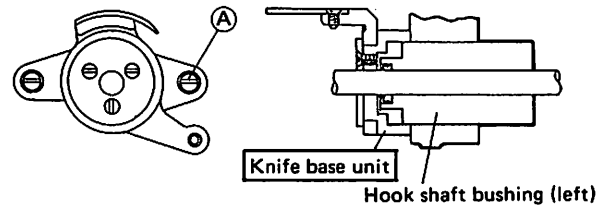

Fig. 2

5.1.3.2 Fixed blade bracket unit

- (1) As shown in Fig. 3, install the fixed blade bracket unit with the hook positioner dismantled, and then fix with the screws (A).

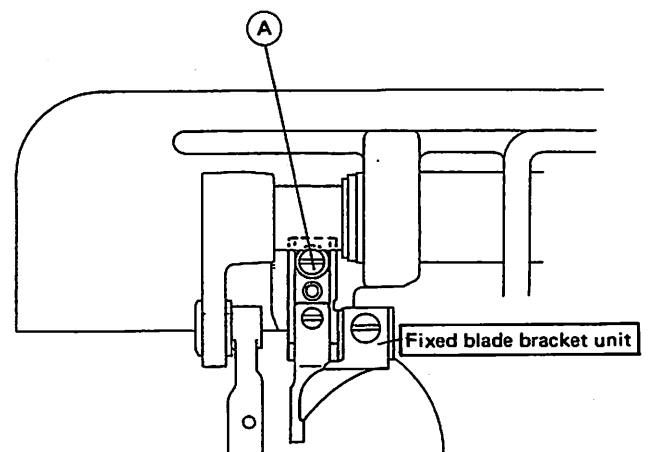

Fig. 3

5.1.3.3 Relation between fixed blade and movable knife (left) edge

(1) Fig. 4 shows the standard state.

(2) If the dimension indicated in Fig. 4 is too large, three-thread breakage will occur, leading to needle thread cast-off, etc. after the thread trimming. Reversely, if the dimension is too small, thread trimming error may result. Therefore, caution must be exercised.

(3) Make the adjustment in (2) in the installation procedure of fixed blade bracket unit or in the installation procedure of fixed blade.

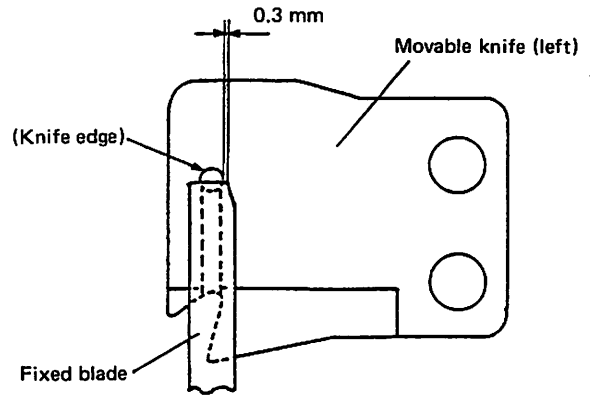

Fig. 4

5.1.4 Connection of knife base and knife driving crank

(1) Make connection as shown in Fig. 5. At this time, use care for the position of link depends on the sewing machine model.

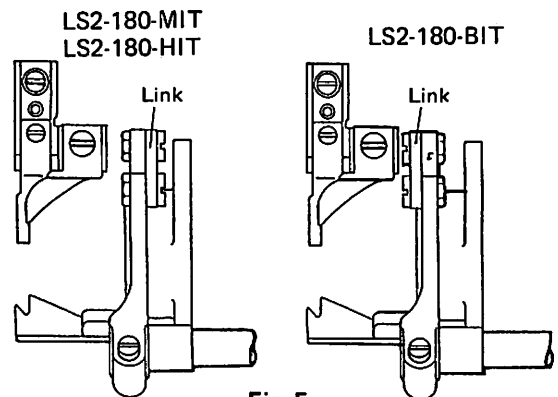

Fig. 5

5.1.5 Knife driving shaft and related parts

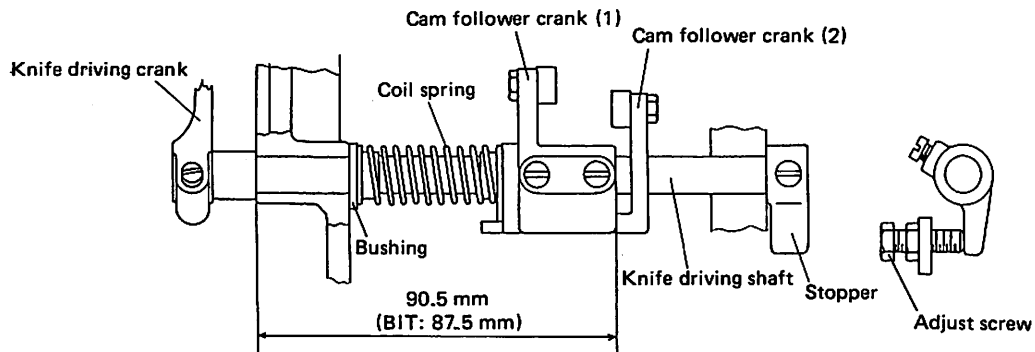

Fig. 6

(1) Fig. 6 shows the standard setting position.

(2) During assembling, be sure to pass the knife driving shaft through the knife driving crank first.

(3) Fix the cam follower crank (1) to the recess of knife driving shaft at the position shown in Fig. 6.

(4) Fix the stopper to the recess so that the knife driving shaft can rotate smoothly without play in the axial direction.

5.1.6 Installation of thread trimmer solenoid unit

(1) Operation stroke of thread trimmer solenoid

- ① Standard operation stroke is 3.7 mm.
- ② Adjust the operation stroke by use of the nut (A).

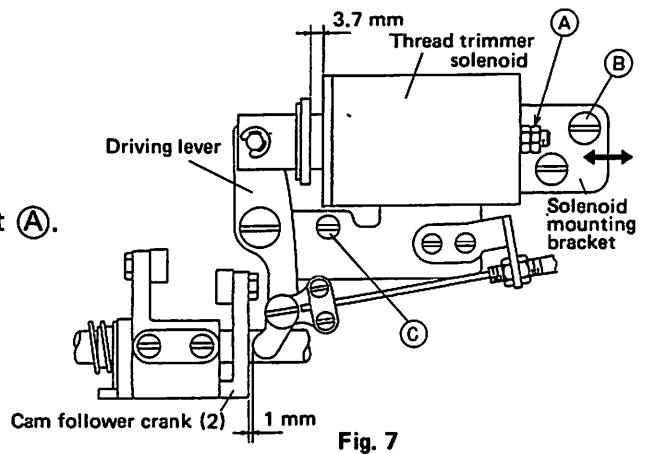

Fig. 7

(2) Installation of unit

- ① Install the unit with the screws (B) and (C) shown in Fig. 7.
- ② Install the unit so that approximately 1 mm is provided between the driving lever and cam follower crank (2) with the stopper nut (A) in contact with the solenoid.
- ③ When the solenoid is energized under this condition, clearance of 0.5 mm is provided between the cam follower cranks (1) and (2) as shown in Fig. 8. This is the standard installation status. Make adjustment by moving the solenoid mounting bracket in the arrow direction in Fig. 7.

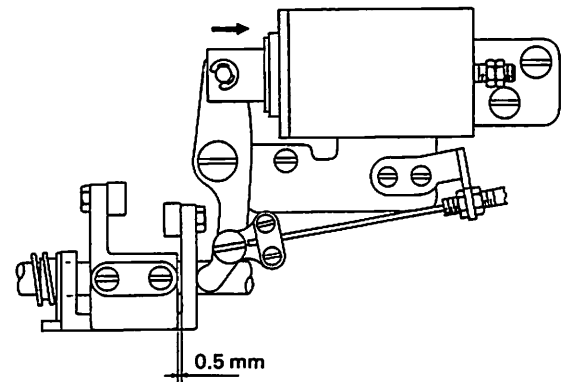

Fig. 8

5.1.7 Installation of thread trimmer cam

- (1) Align the second timing mark (A) on the pulley with the matching mark on the arm.
- (2) Set the thread trimmer solenoid to the operation state and turn the thread trimmer cam forward. At the point where the cam makes contact with the roller, fix the cam.
- (3) When the operation of thread trimmer solenoid has been reset and the cam follower crank (2) has returned, the standard clearance between the cam and roller end is 0.5 to 1.0 mm.

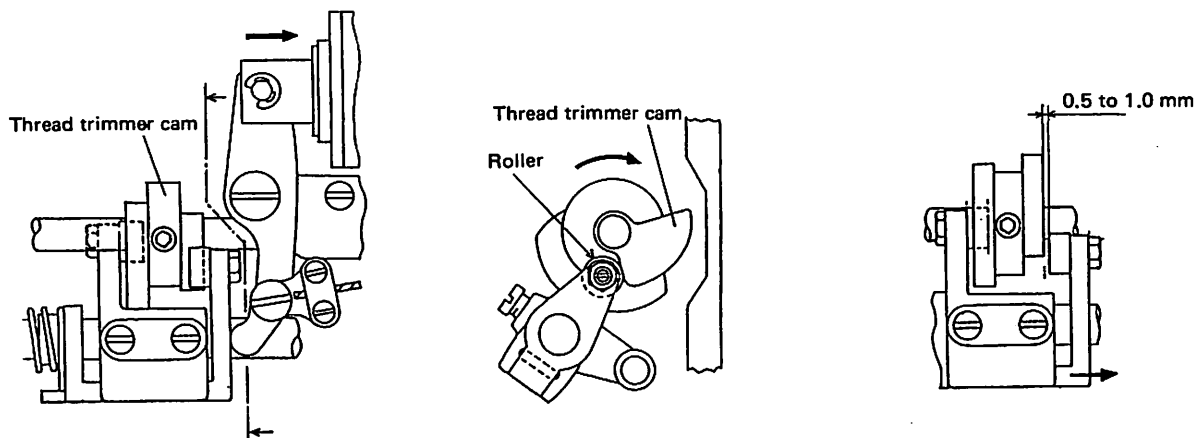
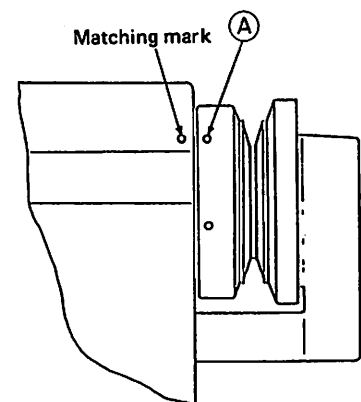

Fig. 9

Note: The standard position of cam follower crank (2) prior to the operation is shown in Fig. 10. When this position has been changed, for example, by removing the stopper plate, make adjustment with the adjust screw (Fig. 6) and then make adjustment in (1) to (3).

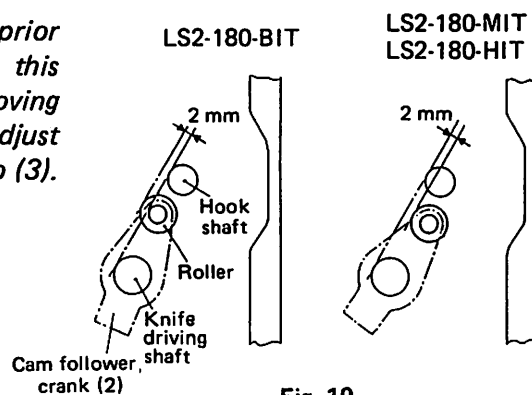

Fig. 10

5.1.8 Adjustment of knife engagement

(1) Positions of movable knife (left) and fixed blade

- ① Fig. 11 shows the standard state.

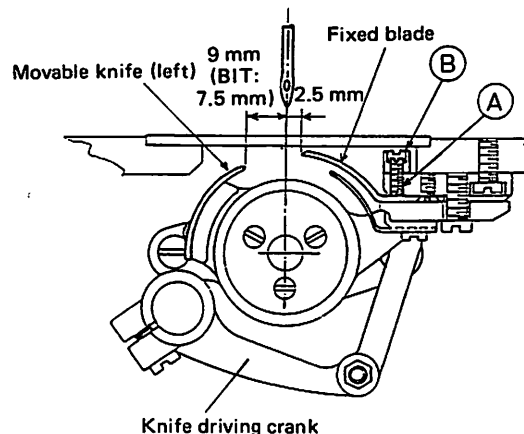

Fig. 11

(2) Adjustment of knife engagement amount

- ① Set the solenoid to the operation state and rotate the sewing machine. Then, the movable knife (left) is rotated by the thread trimmer cam. When the movable knife (left) has moved to the maximum, the standard engagement amount is 1.5 to 2.0 mm. See Fig. 12.
- ② Make adjustment by the installation of knife driving crank.

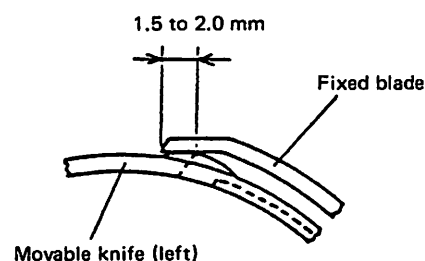

Fig. 12

(3) Adjustment of knife engagement pressure

- ① The standard knife engaging pressure is obtained when the movable knife (left) and fixed blade start making contact with each other at the position shown in Fig. 13.
- ② When cutting action is poor especially because of thick thread, a slight increase of the engagement pressure produces an effect.
- ③ To adjust the engagement pressure, loosen the lock nut (B) in Fig. 11 and adjust with the adjust screw (A).

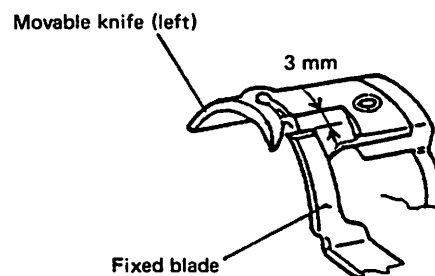

Fig. 13

5.1.9 Adjustment of needle thread tension releasing amount

- (1) Make adjustment so that when the thread trimmer solenoid is operated, the tension discs of thread tension regulator open approximately 1 mm.
- (2) To make adjustment, loosen the nuts (A) and move the flexible wire.

CAUTION

If the opening of tension discs is too small, the needle thread will be trimmed at short length, leading to needle thread cast-off. Reversely, if the opening of tension discs is too large, the tension discs are left opened continuously, leading to loose stitches.

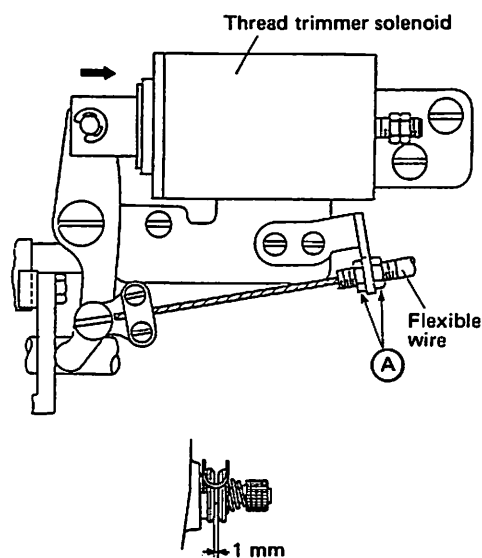

Fig. 14

5.2 Adjustment of Needle Thread Remaining Length

- (1) Adjust the remaining length of needle thread by use of the pretension adjust nut (A).
Clockwise turn reduces the remaining length. Counterclockwise turn increases the length.

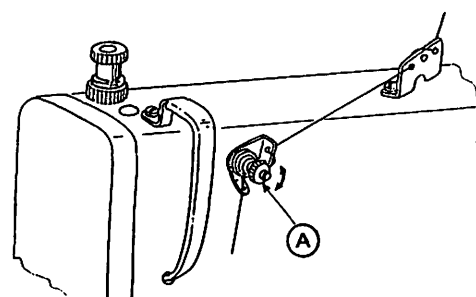

Fig. 15

5.3 Cautions on Installation of Touch-Back Solenoid

Adjust the position of solenoid in the longitudinal direction so that the plunger of solenoid and the link (for connection) are not twisted, and make sure that the reverse sewing lever moves smoothly in the vertical direction. After that, tighten the mounting screws. See Fig. 16.

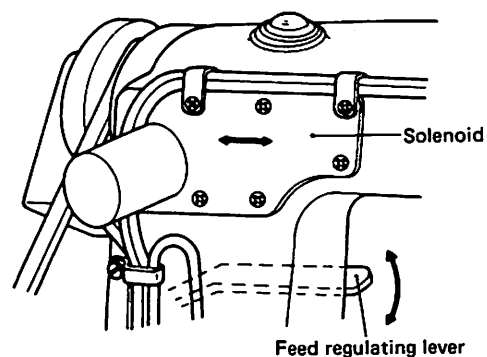

Fig. 16

5.4 Touch-Back Pushbutton

The function of pushbutton can be eliminated as required.

- (1) Normally, this pushbutton is used at the position shown in Fig. 17. When the sewing machine is operated after the pushbutton is pressed, reverse stitching is performed.
- (2) When the pushbutton is moved to the position indicated by the broken line in Fig. 17, the switch does not function even if it is pressed.

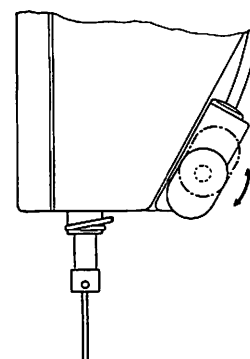
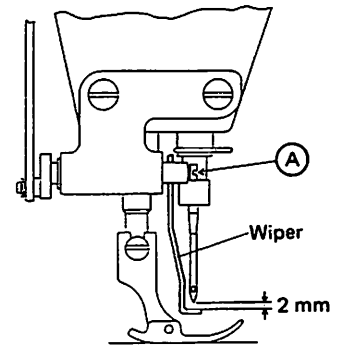

Fig. 17

5.5 Wiper

5.5.1 Height of wiper

- (1) The standard height of wiper is 2 mm below the tip of needle which is stopped at the UP position.
- (2) Make adjustment after loosening the screw (A).



5.5.2 Wiper operation position

- (1) The standard operation position of wiper is 0 to 2 mm from the center of needle when the plunger of wiper solenoid is fully pushed (when the solenoid is energized).
- (2) To make adjustment, loosen the screws (B) and (C) and then adjust the mounting position of solenoid unit.

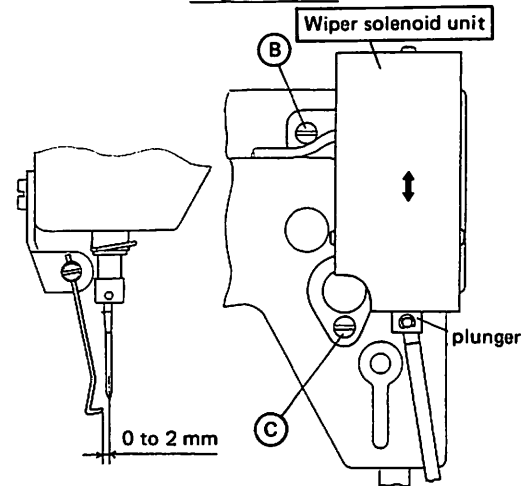

Fig. 18

5.6 Adjustment of Forward and Reverse Stitch Lengths

- (1) Loosen the screw (A) and make adjustment by turning the eccentric shaft (B). Clockwise turn reduces the forward stitch length and increases the reverse stitch length. Counterclockwise turn increases the forward stitch length and decreases the reverse stitch length.

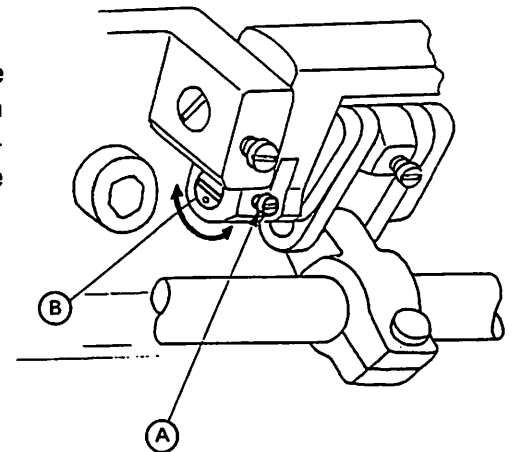

Fig. 19

5.7 Adjustment of Feed Dog Inclination

- (1) To adjust the inclination of feed dog, loosen the screw (A) and turn the eccentric pin (B). Clockwise turn sets to downward tilt. Counterclockwise turn sets to upward tilt.

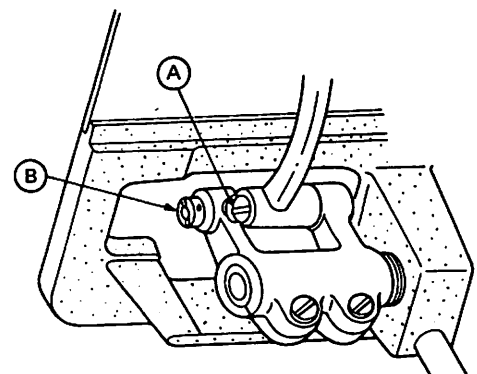

Fig. 20

5.8 Timing of Feed

- (1) The position for the standard feed timing is where the needle tip is located approximately 3 mm below the top surface of needle plate when the feed dog is sunk by turning the pulley and the teeth of feed dog align with the upper surface of needle plate. See Fig. 21.
- (2) Make adjustment by the mounting positions of feed lifting cam feed cam.

1) Installation of feed lifting cam

To install, align the center of oil hole (C) in the arm shaft with that of the second screw (B) in the feed lifting cam.

2) Installation of feed cam

To install, set the third screw (A) of feed cam with respect to the second screw (B) of feed lifting cam as shown in Fig. 21.

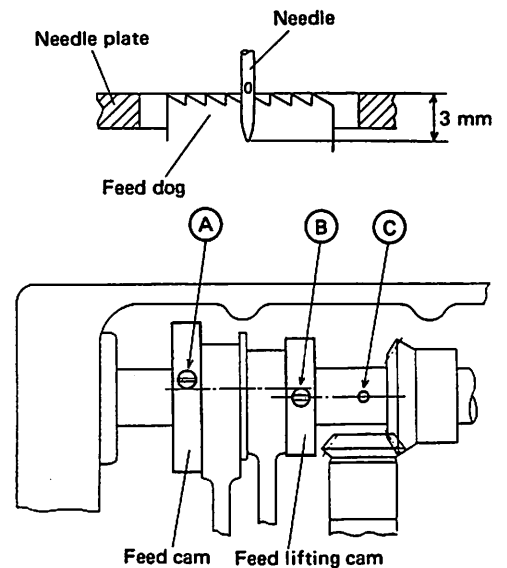

Fig. 21

5.9 Hook, Bobbin Case, and Bobbin

- (1) Use the undertrimmer hook which has the bobbin thread guide slit (A) as shown in Fig. 22.

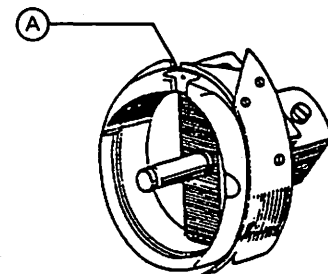

Fig. 22

- (2) Use the bobbin case which has idel running prevention spring (A) at the bottom as shown in Fig. 23.

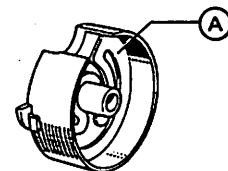

Fig. 23

- (3) For the bobbin, use the attached bobbin. The standard bobbin of Model -M sewing machine is made of aluminum. In order to prevent the deformation of bobbin, wind the thread as lightly as possible.

6. TROUBLESHOOTING

| Trouble | Cause | Corrective Action | Reference Section |
|--|---|--|-------------------|
| Thread cannot be trimmed. | Knife engagement is improper. | Adjust the engagement amount. | 5.1.8 |
| | Knife engaging pressure is too low. | Adjust the engaging pressure. | 5.1.8 |
| | Damage and/or wear of cutting edge of movable knife (left), fixed blade | Change the knife and/or blade. | |
| | Machine stops too early. | Adjust the stop position. | 4.2 |
| | Machine stop position varies largely. | 1. Check needle thread tension at the time of thread trimming. 2. In the case of Model -H or -B machine, check table specifications (motor pulley diameter, control box G switch ON). | 5.1.9 |
| | Position of fixed blade is improper. | Adjust the position of fixed blade. | 5.1.3 |
| | Since the movable knife (left) is operated too early, loop spreading cannot be performed by the knife. | Adjust the installation of thread trimmer cam. | 5.1.7 |
| Needle thread comes out of the needle at the start of stitching. | At the time of thread trimming, thread tension regulator discs do not open. | Adjust the needle thread tension releasing. | 5.1.9 |
| | Thread trimmer timing is too early. | Adjust the installation of thread trimmer cam. | 5.1.7 |
| | Thread is trimmed by the fixed blade before the cutting edge of movable knife (left) engage with the fixed blade. | Adjust the position of fixed blade. | 5.1.3 |
| | Needle is too thick with respect to the thread. Pretension is too strong. | Adjust the pretension. | 5.2 |
| Skip stitch at the start of stitching | Bobbin thread becomes short due to the idle running of bobbin at the thread trimming. | Use a bobbin case with idle running prevention spring. | 5.9 |
| | Tension of bobbin thread is too high. | Adjust the tension of bobbin thread. | |
| | The remaining length of needle thread on the needle side is too short after thread trimming. | 1. Adjust the pretension. 2. Check the installation of thread trimmer cam. 3. Check the thread contact area. | 5.2 5.1.7 |
| Needle thread is too long after thread trimming. | Pretension is too weak. | Adjust the pretension. | 5.2 |
| | Thread trimmer timing is too late. | Adjust the installation of thread trimmer cam. | 5.1.7 |
| | Thread movement between the hook and the hook positioner is not smooth. | | |



MITSUBISHI ELECTRIC CORPORATION

HEAD OFFICE: MITSUBISHI DENKI BLDG MARUNOUCHI TOKYO 100 TELEX: J24532 CABLE MELCO TOKYO
NAGOYA WORKS : 1-14 , YADA-MINAMI 5 , HIGASHI-KU , NAGOYA , JAPAN